

## Outline installation & maintenance instructions

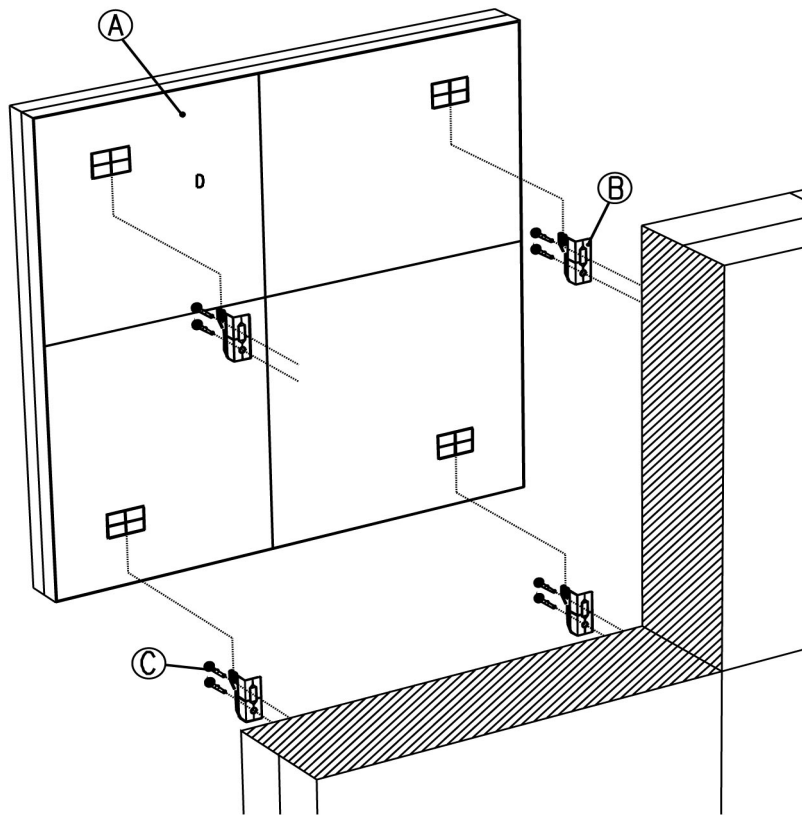

### Key

Component	Qty
<b>A</b> Radiator	1
<b>B</b> Wall mounting brackets	4 as standard, 6 or 8 on larger radiators (these are attached to radiator manifold with ties for transit)
<b>C</b> Screws*	2 per bracket

\* Screws and wall plugs are not supplied with radiator. Screws must be selected according to wall material and construction, i.e. brickwork, plasterboard, wood panelling etc. The maximum design loading per fixing is 8kg.

### Tools required

Valves (contact your distributor for valves aesthetically matched to radiator)  
 Allen key or spanner to suit valves  
 PTFE tape (high density tape is preferred)  
 Tape measure  
 Spirit Level  
 Electric Drill  
 Masonry drill bit to suit wall plug or screw size (Eskimo brackets will take screws up to 7mm in diameter)  
 Screws & Wall plugs as required  
 Screwdriver  
 Bleed Key

**\*\*Gong radiators – Eskimo supplies cotton jeweller’s gloves with these finishes; please ensure your installer wears these at all times to avoid unnecessary cleaning after installation**

## Installation Instructions

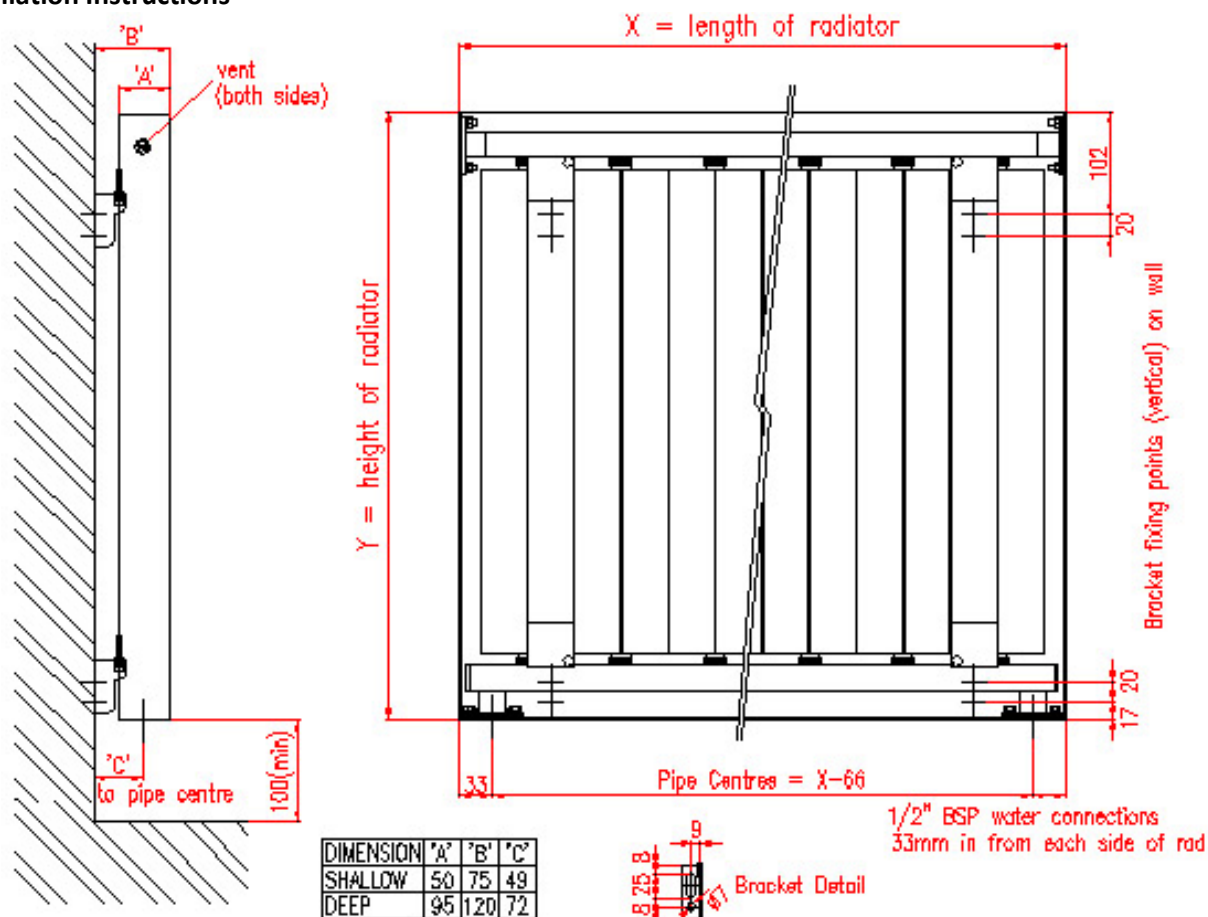

- Before starting work, ensure working area is free of obstructions and objects that could cause harm to you or the radiator. Unpack radiator carefully but **do not fully remove protective plastic film until installation is complete, if necessary unpeel film to check for transit damage then replace.** If laying the radiator onto the floor, place it with the back (aluminium heat exchanger) face to the floor, unless you can ensure that there is nothing underneath that could cause damage to the flat panel face – grit or foreign objects can scratch the flat panel through the protective film.
- Apply sufficient PTFE tape to valve tail threads to provide a leak-tight seal.
- Screw valve tails into threaded pipe connections on radiators **please note, the female aluminium threads in the radiator can be damaged by cross-threading of the valve tails – ensure that thread is correctly aligned before tightening.** Do not over-tighten.
- Measure horizontal bracket positions on back of radiator, vertical positions are shown on drawing above. Refer this to bracket mounting holes and accurately mark out hole positions on wall using a spirit level and tape measure.
- Drill holes *for slotted bracket hole only* in wall as required by screws and wall plugs used.
- Attach brackets (B) to wall initially with one screw only through slotted hole ensuring the hook is at the top.
- Check brackets for alignment using spirit level, and adjust as necessary, then drill and screw second bracket hole. **It is essential that all brackets align correctly with their corresponding mounting positions on the radiator – the radiator must not be forced onto misaligned brackets or damage may occur causing the radiator to leak.**
- Hang the radiator onto the brackets ensuring all brackets are fully engaged. **Radiators are a heavy item, and many of the radiators in our range require more than 1 person to lift them safely. Never attempt to mount a radiator that you cannot comfortably lift.**
- System design, flushing and dosing must be in accordance with BS5449: 1990, BSEN12828, 2003 and BS7593:1992., paying particular attention to the flushing of the system and the dosing of the system with a corrosion inhibitor compatible with aluminium – Eskimo recommend Fernox F1, formulated for mixed metal systems. **Remove protective plastic film before subjecting radiator to heat.**
- If installation problems arise, please refer to the Eskimo website for more detailed information, specifically on the correct venting and system balancing procedure. If problems persist, please contact the Eskimo technical department – the number is shown at the top of this page.
- Brushed stainless steel can be cleaned with baby oil, mirror stainless steel with a glass mirror cleaner. **Abrasive cleaners should never be used on Eskimo products.**



DECLARATION OF PERFORMANCE  
No. 001CPR 2013-07-01

Outline range heat emitter for use with central heating systems with optional towel rail(s) for drying and warming of towels.

Type Nos: 1010A to 99999999S

For the space heating of domestic and commercial premises as a component of a central heating system.

Designed & manufactured by:  
Eskimo Products Ltd  
Valepits Rd  
Garretts Green Industrial Estate  
Birmingham  
B33 0TD

Compliance System 4 to BS EN 442  
Manufacturing facility certified to BS EN ISO 9001:2008

Essential characteristics	Performance	Harmonised technical specification
<b>4.1 Reaction to fire class</b>	Class A1	BS EN 442: 2004
<b>4.2 Release of dangerous substances (pre-treatment and paint)</b>	The materials in this product do not contain or release any dangerous substances in excess of the maximum levels specified in existing European material standards or any national regulations	
<b>4.3 Pressure tightness – test pressure</b>	> 7.5 bar	
Maximum operating pressure	5 bar	
<b>4.4 Rated thermal output and thermal output in different operating conditions</b>	Dependent upon specific part number supplied, the thermal output is certified as being in accordance with the official Eskimo Products Ltd. published data	
<b>4.5 Durability (resistance to corrosion of the pre-treatment and paint)</b>	Pass	
<b>Durability (corrosion resistance of wetted parts)</b>	Pass	
<b>Durability – fatigue resistance – pressure cycling according to Eskimo Products Ltd standard 3.1</b>	Type > 5475 cycles @ 10 bar Pass	
<b>Durability – fatigue resistance – thermal cycling according to Eskimo Products Ltd standard 3.2</b>	Type > 5475 cycles from 10°C to 90°C Pass	
<b>Maximum operating temperature</b>	95°C	

The performance of the product identified above is in conformity with the declared performance.

The declaration of performance is issued under the sole responsibility of the manufacturer identified above.  
Signed for and on behalf of Eskimo Products Ltd:

Managing Director  
Birmingham, UK, 8<sup>th</sup> February 2024

## Declaration of Conformity

*This declaration of conformity is issued under the sole responsibility of the manufacturer*

Manufacturer's Name: <b>Eskimo Products Ltd</b> Address: Unit 7, Ace Business Park, Mackadown Lane, Birmingham B33 0LD, United Kingdom
Product/Type of Equipment: Central Heating Radiator
Model Name: <b>Outline</b> Type Names: <b>Shallow, Deep</b> Finishes: <b>All</b> , Type Numbers: <b>xxxxxxD-xx to xxxxxxS-xxx</b> (x designates number ranges from 1 to 9 and letters from A to Z)

The designated products are in conformity with the European Directives:

## 2011/65/EU

**All products in the table conform to the Directive (EU) 2015/863 amendment of the RoHS DIRECTIVE 2011/65/EU, Article 4(1): and do not contain any of the below-mentioned 10 Hazardous substances above the specified limits).**

Restricted substances	Maximum Threshold
Cadmium	100 ppm (0.01 weight%)
Mercury	1000 ppm (0.1 weight %)
Hexavalent chromium	1000 ppm (0.1 weight %)
Lead	1000 ppm (0.1 weight %)
Polybrominated biphenyls (PBB)	1000 ppm (0.1 weight %)
Polybrominated diphenyl ethers (PBDE)	1000 ppm (0.1 weight %)
Bis(2-ethylhexyl phthalate (DEHP)	1000 ppm (0.1 weight %)
Benzyl butyl phthalate	1000 ppm (0.1 weight %)
Dibutyl phthalate (DBP)	1000 ppm (0.1 weight %)
Di isobutyl phthalate (DIBP)	1000 ppm (0.1 weight %)

This product is manufactured to CE regulations and conforms to the following standards:

**SAFETY:**

BS EN 442-1:2014

Signed



Philip Ward Managing Director  
 Birmingham

February 8<sup>th</sup>, 2024

