

Woody Hinge & Bracket installation & maintenance instructions

Hinge & Bracket is the world’s first completely concealed thermostatic valve system and is unique to Eskimo’s Outline range of radiators. The radiator is top hung and pivots forward on two brackets, assisted by gas struts which hold the radiator out from the wall while the thermostatic or lockshield valves are adjusted. The radiator is then pushed back against the back where a push-to-close latch engages and holds it in position.

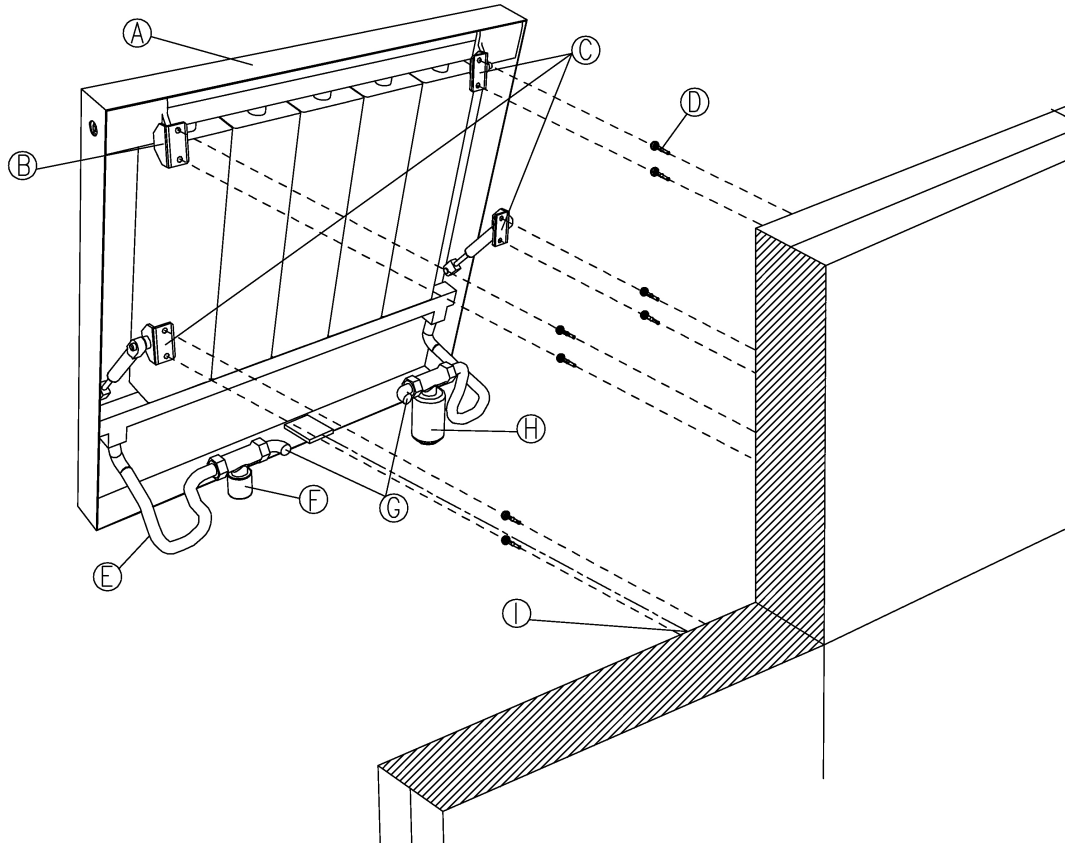

Key (references to left and right are looking from the front of the radiator).

Please note – all drawing dimensions are in millimetres.

Component	Qty
A Radiator	1
B Top right hinge wall bracket (U profile)	1
C Top left hinge & gas strut wall bracket (Z profile)	3
D Screws*	2 per bracket
E Stainless steel braided hoses	2
F Straight Lockshield valve (can be fitted to either connection)	1
G 15mm (copper or plastic) pipe elbows coming from wall (not supplied)	2
H Straight Thermostatic control valve (TRV)	1
I Aluminium catch to engage with push to close latch (screwed to wall)	1

* Screws and wall plugs are not supplied with radiator. Screws must be selected according to wall material and construction, i.e. brickwork, plasterboard, wood panelling etc. The maximum design loading per fixing is 8kg.

Tools required

Spanner to suit valves

PTFE tape (high density tape is preferred) or liquid sealant

Tape measure

Spirit level

Electric drill & driver

Masonry drill bit to suit wall plug or screw size (brackets will take screws up to 6mm in diameter)

Screws & Wall plugs as required

Radiator Bleed Key

Installation Instructions

General

1. Before starting work, ensure working area is free of obstructions and objects that could cause harm to you or the radiator. Unpack radiator carefully but **do not fully remove protective plastic film until installation is complete, if necessary unpeel film to check for transit damage then replace.** If laying the radiator onto the floor, place it with the back (aluminium heat exchanger) face to the floor, unless you can ensure that there is nothing underneath that could cause damage to the flat panel face – grit or foreign objects can scratch the flat panel through the protective film.
2. **Radiators are a heavy item, and most of the radiators in our range require more than 1 person to lift them safely. Never attempt to mount a radiator that you cannot comfortably lift. If you wish to know the weight of the radiator please contact the Eskimo technical department on the helpline shown above. Eskimo will not accept liability for damage to the radiator occurring during installation.**

Stage 1 – installation of pipes

3. Decide upon the position of the radiator on the wall. It is very helpful if the position of the four corners of the radiator can be accurately marked on the wall as all brackets and pipe work can then be easily measured and positioned. It may be possible to protect existing wall coverings and decoration with the use of masking tape. **As this radiator is hinged it is extremely important that the radiator is mounted level on the wall – misalignment of the radiator will put sideways pressure on the gas struts, reducing their lifecycle. Extreme misalignment could cause the gas struts to push against the side of the radiator internally, ultimately causing the radiator or associated pipe connections to leak.**
4. Mark out and install 15mm copper or plastic pipes as shown below. Other pipe diameters can be utilised with appropriate reducers as long as the pipes terminate as 15mm to suit the valves supplied. The pipes should be installed in the wall in accordance with any building regulations.

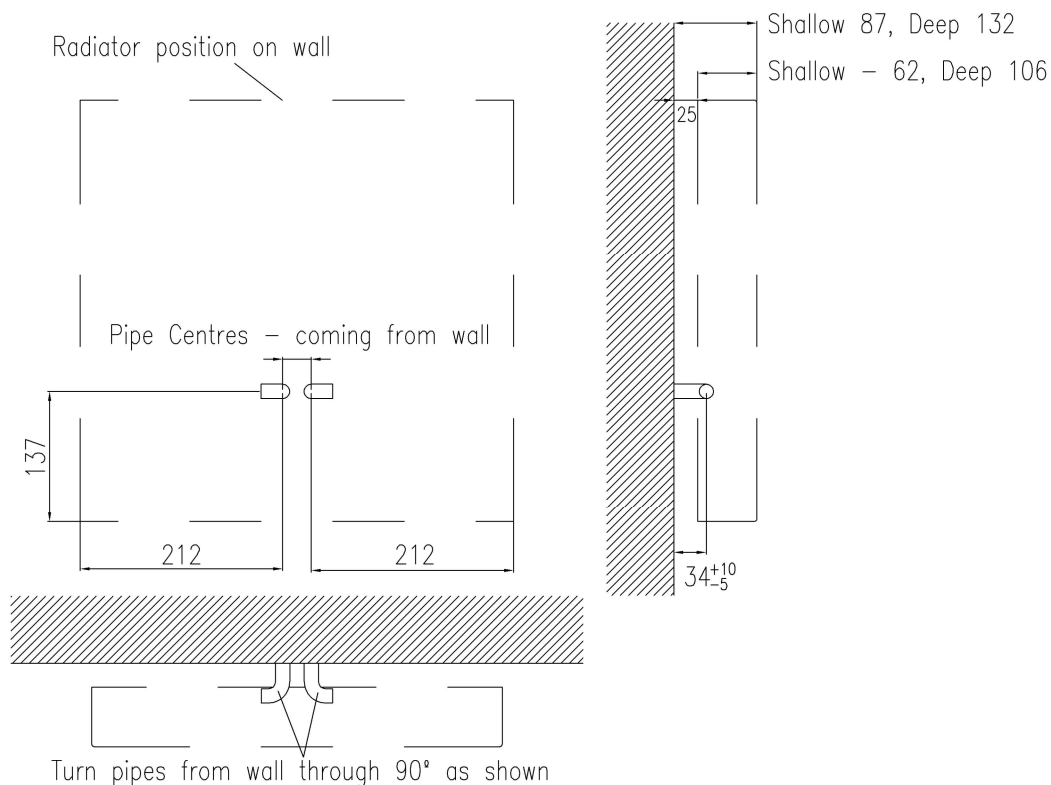

Stage 2 – attaching top hinge brackets to wall

- The radiator is hung on two brackets which act as the hinges upon which the radiator pivots forward to allow access to the valves
- The top right hinge wall bracket is the “U” shaped bracket. The top left hinge wall bracket is one of the three “Z” shaped brackets provided – the other two will be used to attach the gas struts to the wall in stage 3.
- Working from the top corners of the radiator already marked on the wall, mark the bracket positions on the wall as shown on the drawing below then drill and fix them with fixings appropriate to the wall material. Take care to ensure the hinges are completely level.

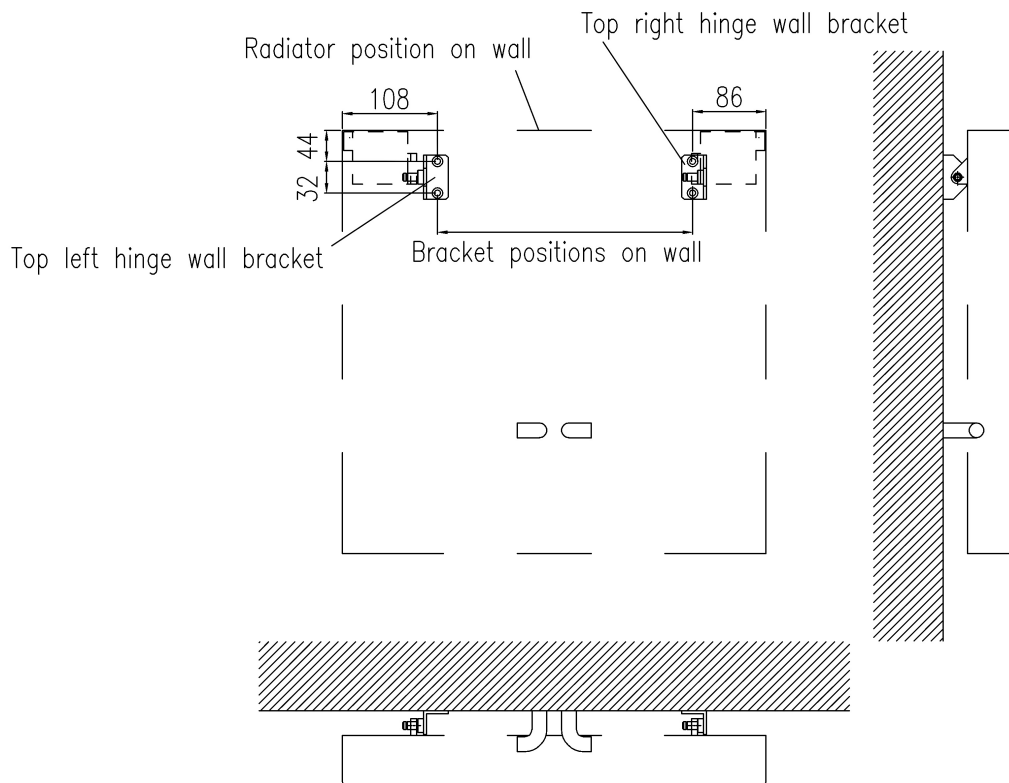

Stage 3 – connecting the valves

- The thermostatic valve set supplied with your Eskimo radiator are bi-directional – this means that either valve, thermostatic (the big one) or lockshield (the small one), can be fitted to either pipe coming from the wall. Connect the valves, as per the separate valve instructions supplied, to the pipe elbows already installed in stage 1. The valve heads should point vertically **downwards**, or at a slight angle outwards to allow for easier adjustment. The critical thing is that no part of the valve should project more than 70mm from the wall for shallow radiators and 115mm for deep radiators.

Stage 4 – connecting the flexible hoses to the radiator

- Now connect the plain threaded end of the stainless steel braided hoses to the ½” female aluminium connections at the bottom of the radiator. These plain threaded hose ends may have been supplied with a nut and olive but these can be removed and discarded. Apply plenty of PTFE tape (high density tape is better) or a good quality liquid sealant and allow to set as per the manufacturer’s instructions. Do not connect the other end of the hoses to the valves at this stage.

Stage 5 – attaching gas strut brackets to wall

10. Locate the two remaining “Z” shaped brackets. Mark their positions on the wall - working from the bottom corners of the radiator already marked on the wall, mark the bracket positions on the wall as shown on the drawing below then drill and fix them with fixings appropriate to the wall material. Take care to ensure the brackets are completely level. **Please note** the +/- 2mm tolerance on the vertical alignment of the gas strut bracket – it is important to adhere to this tolerance to maximise the life of the gas strut and to ensure that it does not rub against the radiator which could ultimately cause the radiator to leak.
11. Now hang the radiator – the two pins on the wall brackets slide into the holes on the top hinge holes on the brackets fixed to the radiator. If you have accurately fixed the brackets in the positions shown then you will find that the right hand bracket engages marginally first allowing you to line up the left hand hinge and push the radiator fully home which is a great deal easier than attempting to line them both up simultaneously. **Please note** – the radiator half of the hinge is bonded to the back of the radiator and will withstand fairly heavy manipulation and very long term use once the radiator is hung. However if the wall brackets are out of line to a high degree, or if the radiator is hung on only one bracket and twisted, or if the radiator is not supported properly during the process of sliding it sideways onto the hinges then damage to the radiator could occur and in extreme conditions the brackets could be ripped off. Eskimo will not accept liability if damage of this type occurs. **Most radiators in this range require 2 people to safely mount them – trying to hang a radiator that is too heavy for you could result in damage to the radiator, the wall or more importantly to you – if in doubt get someone to help.**

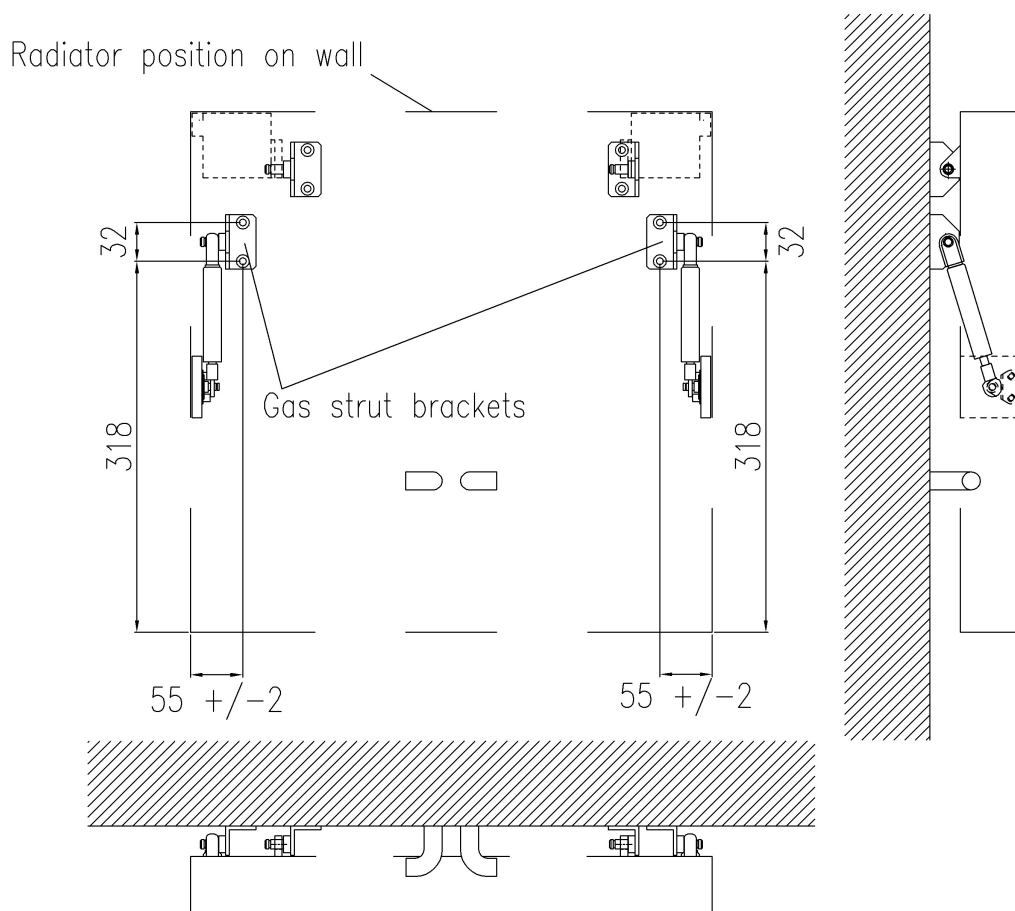

12. Do not put the sprung retaining caps on the wall brackets at this stage.
13. Now attach the gas springs to the wall brackets to check that the alignment is correct. The gas spring pressure is tailored for each radiator and will be within a range that will, partially dependent on temperature, either gently open the radiator under their own force or assist the opening so that just a gentle pull on the bottom of the radiator is required. Under all circumstances the gas struts will hold the radiator open to allow for adjustment to the valves.

Stage 6 – attaching push-to-close aluminium latch to wall

14. Push the radiator closed against the wall
15. You will notice the push to close latch – this needs to be pushed into the closed position. You now need to locate the aluminium hooked latch that will hold it closed against the wall.
16. Place the aluminium latch on the wall with the hook firmly engaged over the roller ball on the catch. This hook holds the radiator to the wall so the positioning needs to be accurate to prevent the roller latch disengaging and allowing the radiator to open. Carefully mark the position of the plastic latch on the wall. Note the drawing below – the centre line of the aluminium latch should be 15mm above the bottom of the radiator. The centre of the slotted hole should be approximately 19mm from the centreline of the radiator and other hole is 7mm further from the centreline. However, due to the importance of accurate positioning of this latch and to allow for manufacturing tolerances it is best to check the actual position of the aluminium latch relative to the roller ball (in the closed position) before fixing the aluminium latch to the wall.
17. Having marked the latch position you can now either just remove the gas struts from their wall brackets and in the case of tall radiators, pivot the radiator far enough away from the wall to allow you to fix the latch to the wall (you will require a helper to hold the radiator while you do this), or in the case of shorter radiators you will need to remove the radiator entirely.
18. Fix the aluminium latch to the wall using either the screws provided or appropriate fixings for the wall material involved.

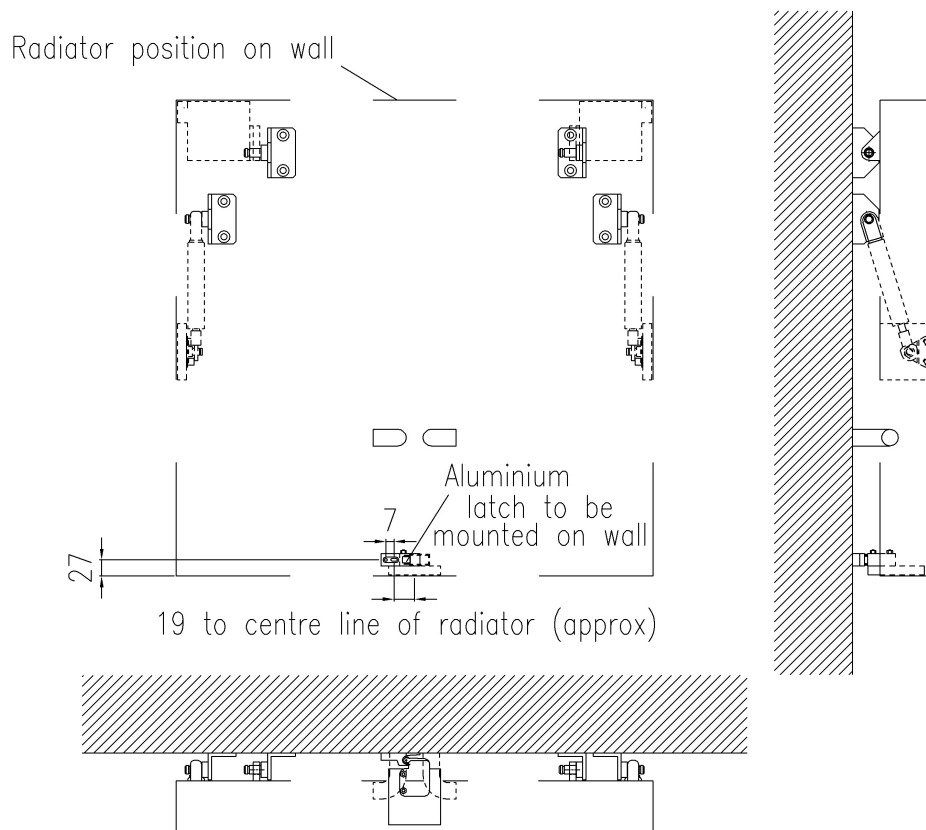

Stage 7 – making the final connections

19. If you removed the radiator from the wall in Stage 6 re-hang it now and re-attach the gas struts to the wall brackets. Using a suitable spanner connect the free ends of the stainless steel braided hoses to the threaded ends of the valves.
20. Fit all 4 sprung retaining caps onto the wall brackets at this stage – these hold the radiator and the gas struts in position. You may require a pair of long-nosed pliers to perform this operation depending upon how accessible the radiator is.

Stage 8 – plumbing and commissioning the radiator

21. System design, flushing and dosing must be in accordance with BS5449: 1990, BSEN12828, 2003 and BS7593:1992. Pay particular attention to the flushing of the system and the dosing of the system with a corrosion inhibitor compatible with aluminium – Eskimo recommend Fernox F1, formulated for mixed metal systems. Remove protective plastic film before subjecting radiator to heat.
22. If installation problems arise, please refer to the Eskimo website for more detailed information, specifically on the correct venting and system balancing procedure. **Close to 100% of issues with radiators not heating up correctly reported to the Eskimo technical department were cured by correct bleeding and balancing of the system.** It should be noted that all Outline radiators are fitted with central baffles that encourage the flow of water around the radiator rather than relying on natural convection for circulation. The baffle is not sealed into place and so a small amount of bypass is possible, meaning that the bottom manifold *can* be hot all the way across without the whole radiator getting hot. If this is the case the radiator either requires bleeding or balancing. Also because of this baffle it is possible that a mixture of air and water is required to be bled from the radiator before all air is vented and the radiator works fully. In that case ensure that a suitable receptacle is placed underneath the corner of the radiator to catch any drips and a towel/sponge is on hand to clear up any spills. If problems persist, please contact the Eskimo technical department – the number is shown at the top of this page.
23. Brushed stainless steel can be cleaned with baby oil, mirror stainless steel with a standard glass mirror cleaner. Abrasive cleaners should never be used on Eskimo products. For other finishes please refer to the Eskimo website or technical department

DECLARATION OF PERFORMANCE
No. 001CPR 2013-07-01

Outline range heat emitter for use with central heating systems with optional towel rail(s) for drying and warming of towels.

Type Nos: 1010A to 99999999S

For the space heating of domestic and commercial premises as a component of a central heating system.

Designed & manufactured by:
Eskimo Products Ltd
Valepits Rd
Garretts Green Industrial Estate
Birmingham
B33 0TD

Compliance System 4 to BS EN 442
Manufacturing facility certified to BS EN ISO 9001:2008

Essential characteristics	Performance	Harmonised technical specification
4.1 Reaction to fire class	Class A1	BS EN 442: 2004
4.2 Release of dangerous substances (pre-treatment and paint)	The materials in this product do not contain or release any dangerous substances in excess of the maximum levels specified in existing European material standards or any national regulations	
4.3 Pressure tightness – test pressure	> 7.5 bar	
Maximum operating pressure	5 bar	
4.4 Rated thermal output and thermal output in different operating conditions	Dependent upon specific part number supplied, the thermal output is certified as being in accordance with the official Eskimo Products Ltd. published data	
4.5 Durability (resistance to corrosion of the pre-treatment and paint)	Pass	
Durability (corrosion resistance of wetted parts)	Pass	
Durability – fatigue resistance – pressure cycling according to Eskimo Products Ltd standard 3.1	Type > 5475 cycles @ 10 bar Pass	
Durability – fatigue resistance – thermal cycling according to Eskimo Products Ltd standard 3.2	Type > 5475 cycles from 10°C to 90°C Pass	
Maximum operating temperature	95°C	

The performance of the product identified above is in conformity with the declared performance.

The declaration of performance is issued under the sole responsibility of the manufacturer identified above.
Signed for and on behalf of Eskimo Products Ltd:



Managing Director
Birmingham, UK, July 1st, 2013

