

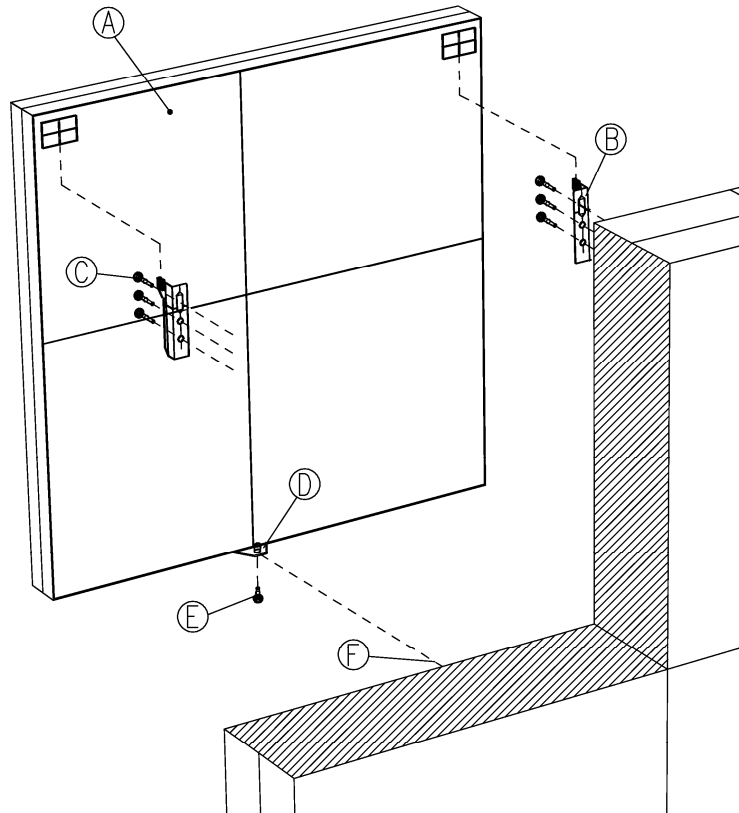

Outline electric installation & maintenance instructions



Key

Component	Qty
A Radiator	1
B Wall mounting brackets	2 (these are attached to radiator manifold with ties for transit)
C Screws*	8 required in total
D Radiator bottom holding bracket	1 (attached to radiator)
E M6 x 12mm capscrew	1
F Wall holding bracket	1 off

* Screws and wall plugs are not supplied with radiator. Screws must be selected according to wall material and construction, i.e. brickwork, plasterboard, wood panelling etc. The maximum design loading per fixing is 8kg.

Tools required

Tape measure
 Spirit Level
 Electric Drill
 Masonry drill bit to suit wall plug or screw size (Eskimo brackets will take screws up to 7mm in diameter)
 Screws & Wall plugs as required
 Screwdriver

Installation Instructions

Radiator depth details	
Radiator Depth	Wall to radiator front face
50	75
95	120

Ensure you leave at least 100mm above radiator free of obstructions to airflow

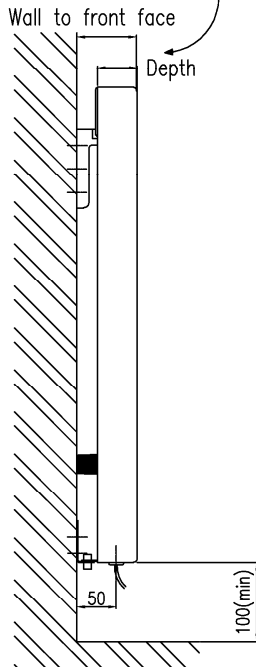

Bracket fixing centres = Radiator length less 110mm (see table)

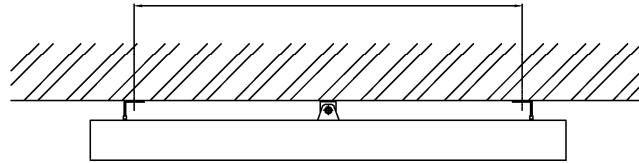

Electric Outline Bracket Centres	
Radiator length	Bracket Centres
240	130
430	320
600	490
800	690
1000	890
1200	1090
1500	1390
1600	1490
2000	1890

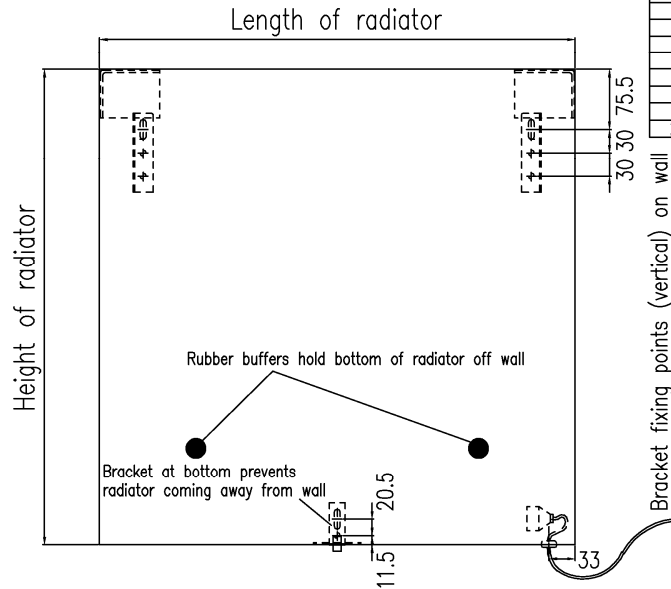

Power flex exits through a gland on the bottom right hand face of the radiator but the flex can be pulled back through the gland to exit directly behind the radiator
Fused spur can be located therefore directly behind the bottom right hand corner of the radiator

1. Before starting work, ensure working area is free of obstructions and objects that could cause harm to you or the radiator. Unpack radiator carefully but **peel off protective plastic film if inspection is required then reapply until installation is complete**. If laying the radiator onto the floor place it with the back (aluminium heat exchanger) face to the floor, unless you can ensure that there is nothing underneath that could cause damage to the flat panel face – grit or foreign objects can scratch the flat panel through the protective film.
2. Bracket fixing positions are shown on the drawing above. Accurately mark out hole positions on wall using a spirit level and tape measure.
3. Drill holes *for slotted bracket hole only* in wall as required by screws and wall plugs used.
4. Attach wall mounting brackets (B) to wall initially with one screw only through slotted hole ensuring the hook is at the top.
5. Check brackets for alignment using spirit level, and adjust as necessary, then drill and screw second and third bracket hole. **It is essential that all brackets align correctly with their corresponding mounting positions on the radiator – these are the stainless steel plates attached to the front panel not the aluminium strips attached to the radiator – hanging the radiator off these will cause it to leak.**
6. Hang the radiator onto the brackets (B) ensuring both brackets are fully engaged. **Radiators are a heavy item, and many of the radiators in our range require more than 1 person to lift them safely. Never attempt to mount a radiator that you cannot comfortably lift.**
7. With the radiator in place (the rubber buffers will hold the radiator the correct distance from the wall) attach the radiator bottom holding bracket (D) to the wall holding bracket (F) with the M6 x 12 capscrew (E) then mark the position of bracket (F) on the wall. Lift the radiator off the wall, remove bracket (F) from the back of the radiator and place it in the position now marked on the wall. Drill holes and attach bracket (F) to the wall. Re-hang radiator on the wall mounting brackets and again once the radiator is resting against the wall attach the radiator bottom holding bracket (D) to the wall holding bracket (F) with the M6 x 12 capscrew (E)
8. Wire radiator into a fused spur providing a means of isolation in accordance with current ISO standards. **Remove protective plastic film before subjecting radiator to heat.**
9. If installation problems arise, please refer to the Eskimo website for more detailed information. If problems persist, please contact the Eskimo technical department – the number is shown at the top of this page.
10. Brushed stainless steel can be cleaned with baby oil, mirror stainless steel with a mirror cleaner. **Abrasive cleaners should never be used on Eskimo products.**