

Ron installation & maintenance instructions

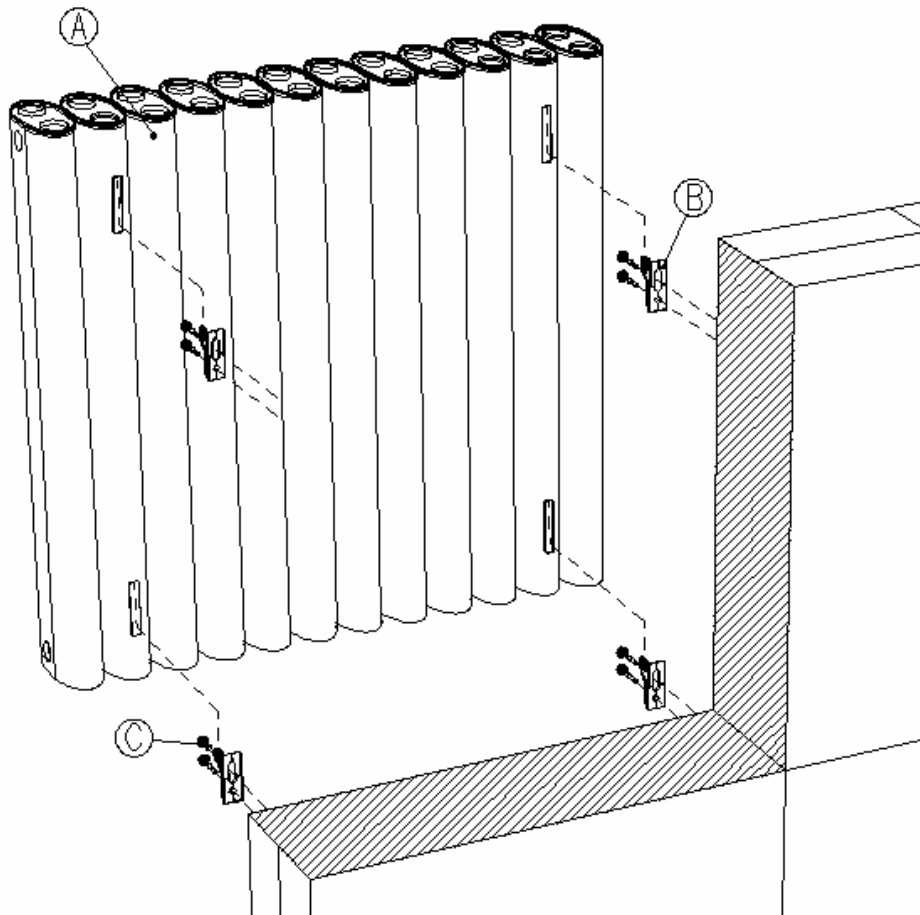

Key

Component	Qty
A Radiator	1
B Wall mounting brackets	4 as standard, 6 or 8 on larger radiators (these are attached inside radiator with ties for transit)
C Screws*	2 per bracket

* Screws and wall plugs are not supplied with radiator. Screws must be selected according to wall material and construction, i.e. brickwork, plasterboard, wood panelling etc. The maximum design loading per fixing is 8kg.

Tools required

Valves (contact your distributor for valves aesthetically matched to radiator)

Allen key or spanner to suit valves

PTFE tape (high density tape is preferred)

Tape measure

Spirit Level

Electric Drill

Masonry drill bit to suit wall plug or screw size (Eskimo brackets will take screws up to 7mm in diameter)

Screws & Wall plugs as required

Screwdriver

Bleed Key

Note

Clear plastic sheet around the radiator should be opened to check the radiator for transit damage and then replaced until after installation to provide protection on site especially while decorating takes place in the area.

Installation Instructions

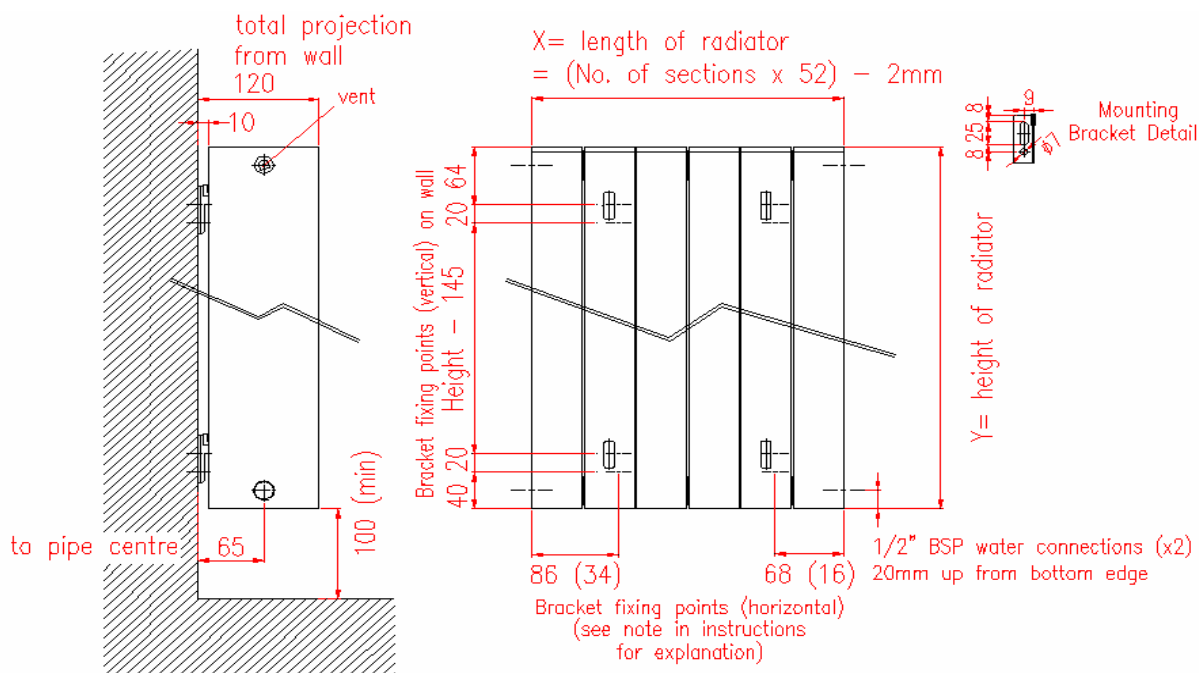

1. Before starting work, ensure working area is free of obstructions and objects that could cause harm to you or the radiator. Unpack radiator (A) carefully. If laying the radiator onto the floor place it with the back face to the floor, unless you can ensure that there is nothing underneath that could cause damage to the front face – grit or foreign objects can scratch the radiator.
2. Apply sufficient PTFE tape to valve tail threads to provide a leak-tight seal.
3. Screw valve tails into threaded pipe connections on radiators **please note, the female aluminium threads in the radiator can be damaged by cross-threading of the valve tails – ensure that thread is correctly aligned before tightening.** Do not over-tighten.
4. Mark out bracket fixing points on wall as per installation drawing above. **Please note: the 86 & 68mm horizontal fixing positions shown above do not apply to radiators with fewer than 4 sections. In this case radiator brackets are not set in 1 section as shown above – the radiator is instead hung on the extreme outside two sections. If this is the case use the dimensions shown in brackets.**
5. In the case of long radiators (Y being greater than 1000mm) weighing over 30kg, additional fixing points are used in the centre of the radiator with extra brackets provided. If this is the case, measure the horizontal centres of the extra fixing points on the back of the radiator, then mark these positions onto the wall in addition to the 4 bracket fixing points as shown on the drawing.
6. Drill holes for slotted bracket hole only in wall as required by screws and wall plugs used.
7. Attach brackets (B) to wall initially with one screw (C) only through slotted hole ensuring the hook is at the top.
8. Check brackets for alignment using spirit level, adjust as necessary, drill and screw 2nd bracket hole.
9. Hang the radiator onto the brackets ensuring all brackets are fully engaged. Use the slots at the back of the radiators for hanging the radiator. **Radiators are a heavy item, and many of the radiators in our range require more than 1 person to lift them safely. Never attempt to mount a radiator that you cannot comfortably lift.**
10. Plumb radiator into heating circuit in accordance with current ISO standards, paying particular attention to the flushing and dosing of the system with a corrosion inhibitor compatible with aluminium – Eskimo recommend Fernox MB-1, formulated for mixed metal systems.
11. If installation problems arise, please refer to the Eskimo website for more detailed information, specifically on the correct venting and system balancing procedure. If problems persist, please contact the Eskimo technical department – the number is shown at the top of this page.
12. Polished aluminium can be cleaned with warm soapy water on a soft lint free cloth and then dried thoroughly. Brasso or a similar product can be used to polish out small marks.
13. Painted Rons have the welds at the bottom of the radiator masked off prior to painting as part of the test procedure – this will leave a small area of bare aluminium underneath the radiator – this is in no way detrimental to the function of the product and will not be seen after installation.